

# Powerful Pre-assessment

W  
STZ  
Z K L M N S  
O P S G R G B S Z T  
J K L M X D P O L S T G A D D  
E S M P J O E L K S P O X Z D S D P Z P O X

before  

WITH LISA VAN GEMERT  
GIFTEDGURU.COM

1

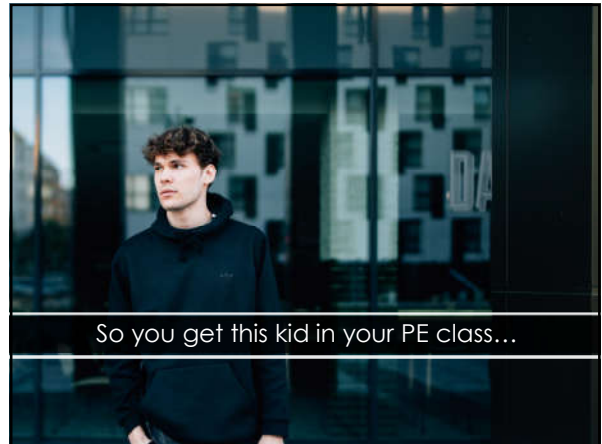

So you get this kid in your PE class...

2

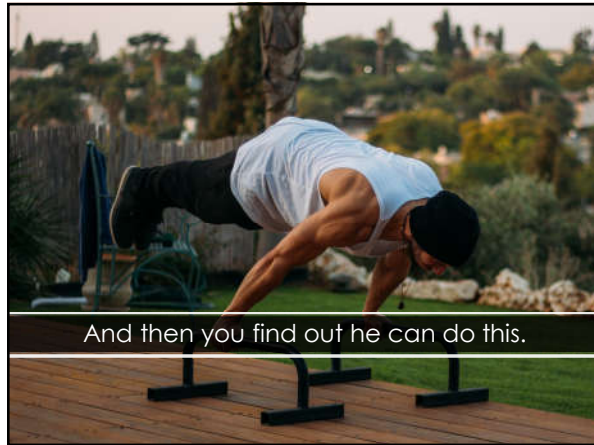

And then you find out he can do this.

3

How many can you do?



4

There's a range.



Activity	Score	Time
The Bruce Up	71	1:00
The Sit Up	78	1:00
The Zomba Ring	13:00	15:00

5

The teacher's job should resemble that of a water-skiing boat driver, and that job is two-fold: to drive the boat and to check the skiers."

-Doubet

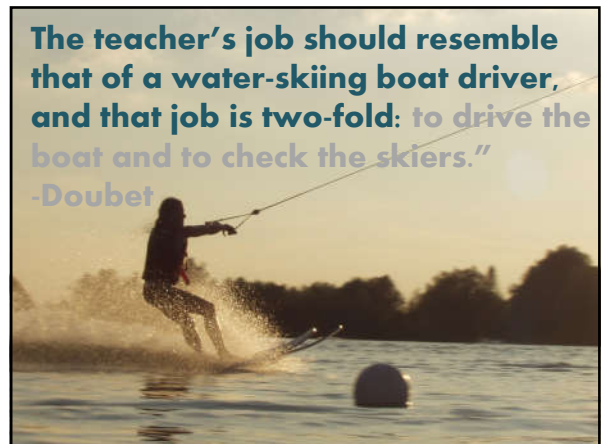

6

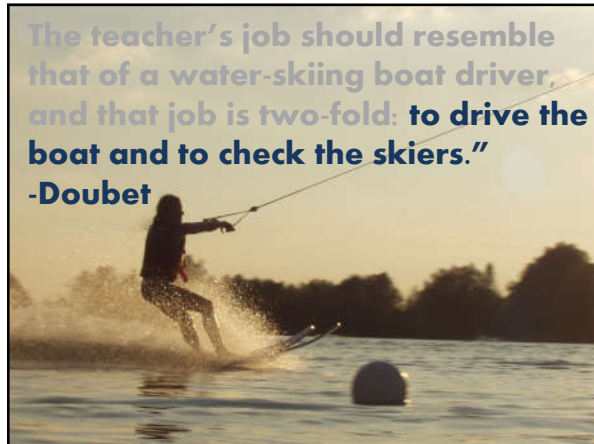

7

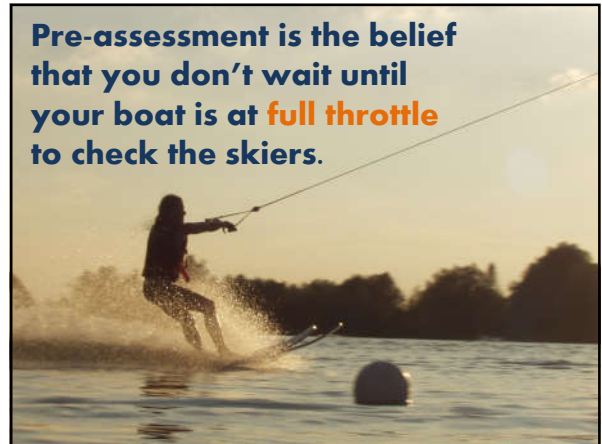

8

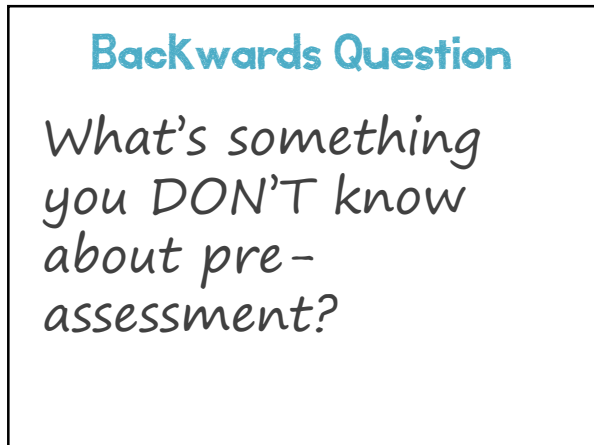

9

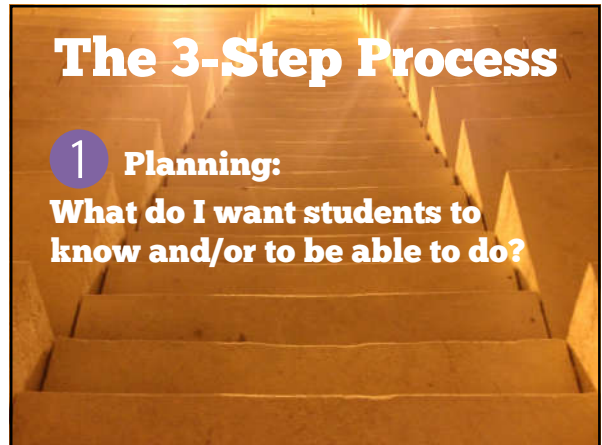

10

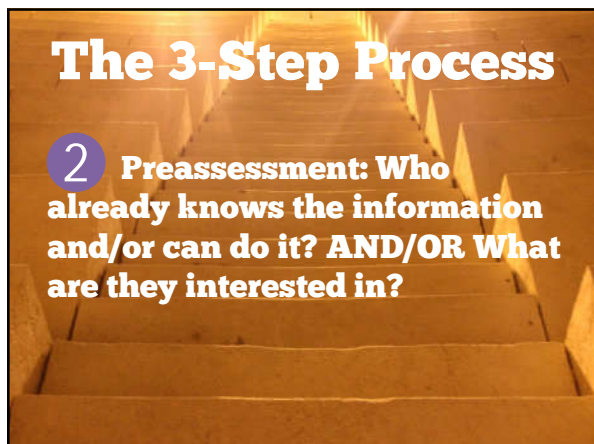

11

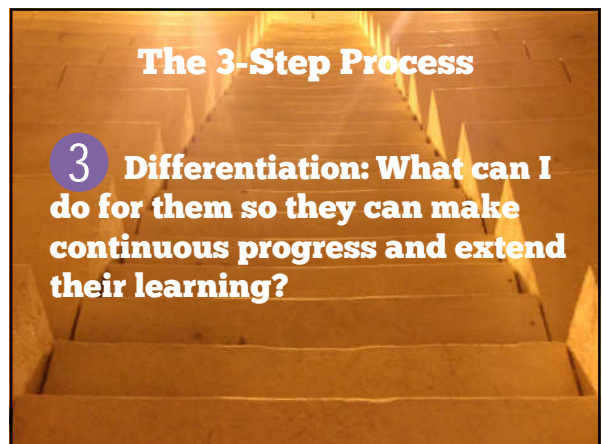

12

**Pre-assessment is a change agent. You do it so you can change something.**

13

**You're Looking For...**

**Subject matter knowledge**

14

**You're Looking For...**

**Mastery of information they know & information they can find**

15

**You must decide...**

**The level of knowledge that will count as mastery**

16

**You're Looking For...**

**Reasoning - the ability to use what they know to solve problems & make decisions**

17

**Because it's more than "book learnin'."**

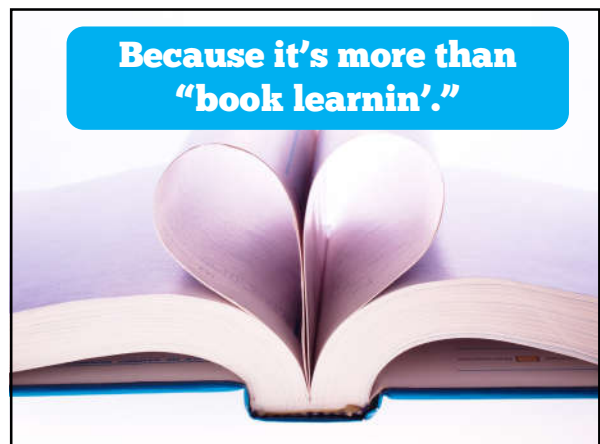

18

**You're Looking For...**

**Skills - the development of proficiency based on doing, not knowing**

19

**You Must Decide...**

**What skills should the student demonstrate to show mastery?**

20

**You're Thinking About**

**Product - the ability to use the skills to create a tangible product**

21

**You Must Decide...**

**What should the student be able to produce to show mastery?**

22

*Keep pre-assessment brief so you have time and energy for instruction.*



23

*Keep pre-assessment limited enough to get good data [1-2 weeks' worth of work, not an entire unit].*

24

Don't ask what everyone knows the answer to. Get to the meat of the issue. What mistakes do they make?

25

It may be formal or informal.

26

## METHODS of PRE-ASSESSMENT

27

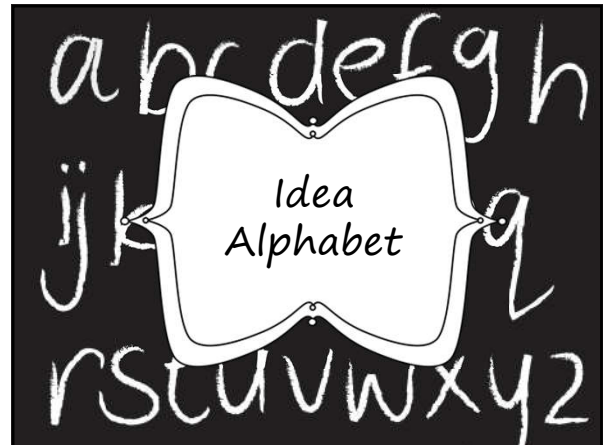

28

### Letter, Listen & Learn

Letter A - Z  
As we go through,  
Check ones you already use.  
Star ones you want to try.  
Line out ones that aren't a good fit.

29

### A. Agree/Disagree



30

- ALL STATE GOVERNMENTS USE A TWO-CHAMBER LEGISLATURE (HOUSE & SENATE).
- HYDROGEN IS THE MOST COMMON ELEMENT.
- CONFLICT IN A STORY ALWAYS RESULTS IN A DECISION.
- YOU CAN ADD TWO INTEGERS & STILL HAVE LESS THAN ZERO.
- THE FIRST STEP IN THIS PROBLEM IS...

31



32

**B. Backwards Questions**

WHAT DON'T YOU KNOW ABOUT ...?

WHAT HAVE YOU LEARNED BEFORE BUT FORGOT?

33

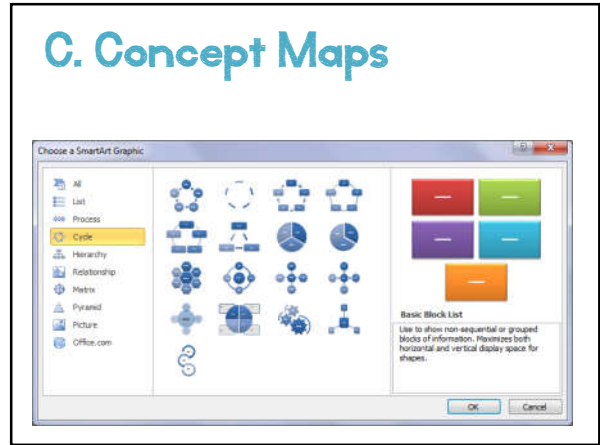

34

Name \_\_\_\_\_ Date \_\_\_\_\_ Passage 27

**Helpful Houseplants**

They sit on a desk or table and look pretty. You need to remember to water them. But what are houseplants actually good for? Fill in the blanks to find out.

Scientists say houseplants do more than \_\_\_\_\_ homes and offices. They can also improve the \_\_\_\_\_ of the air we breathe. Buildings today are often airtight and have plenty of \_\_\_\_\_. This makes them energy-efficient, but it also makes it hard for fresh air to enter.

Many houseplants can "clean" the stale air trapped inside buildings. Plants leaves take in the carbon dioxide gas from the air. In return, they give out clean \_\_\_\_\_.

Plants also take other dangerous gases from the air. For instance, a type of daisy takes in benzene, a \_\_\_\_\_ found in gasoline. Spider plants take in carbon monoxide. So why not keep a lot of houseplants around? They just might help you breathe easier.

**Word List**

- chemical
- decorate
- insulation
- oxygen
- quality

**This one's from Scholastic.**

**Think About It!** What are some benefits of houseplants?

35



36

### E. Entrance/Exit Cards

WHAT IS IRONY? GIVE ME AN EXAMPLE.

EXPLAIN THE ORDER OF OPERATIONS TO ME LIKE I'VE NEVER HEARD OF IT BEFORE.

37

### F. Fun Facts

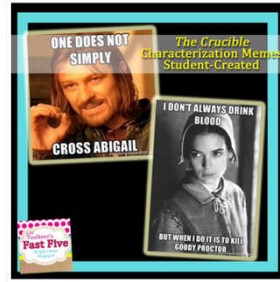

<http://faulknersfastfive.blogspot.com/>

LIST ALL OF THE FACTS YOU CAN IN 2 MINUTES, MAKING THEM AS FUNNY AS YOU CAN.

38

### G. Guessing Games

I'm thinking of a literary element that can...  
I'm thinking of a landform that...  
I'm thinking of a migration that occurred...  
I'm thinking of a set of numbers that...  
I'm thinking of the next step after...  
I'm thinking of an element that...



39

### H. How-to Instructions

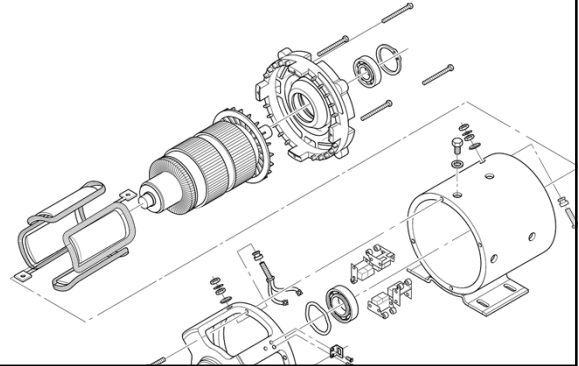

40

### I. Interest Survey



41

### Surveys: Google Forms

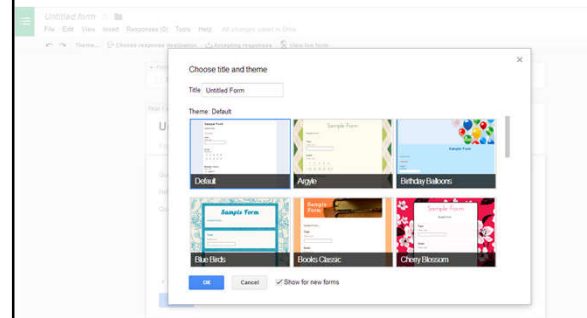

42



43

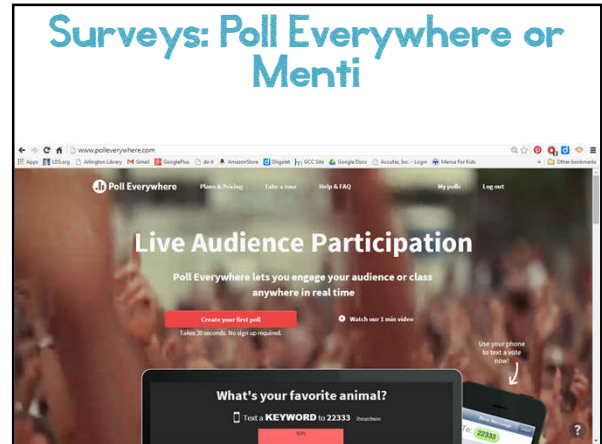

44



45

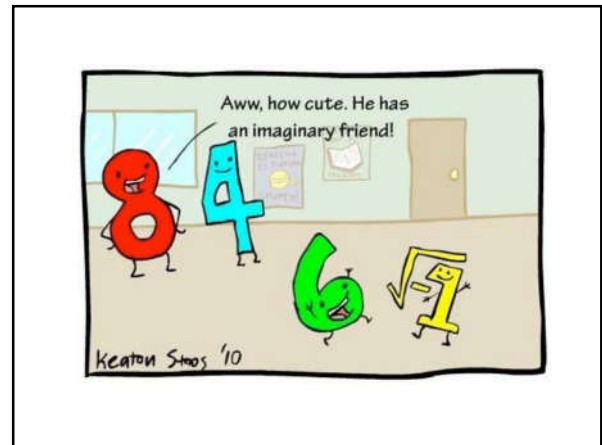

46

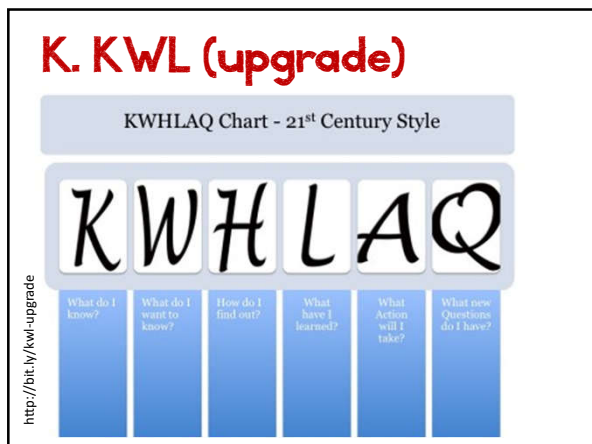

47

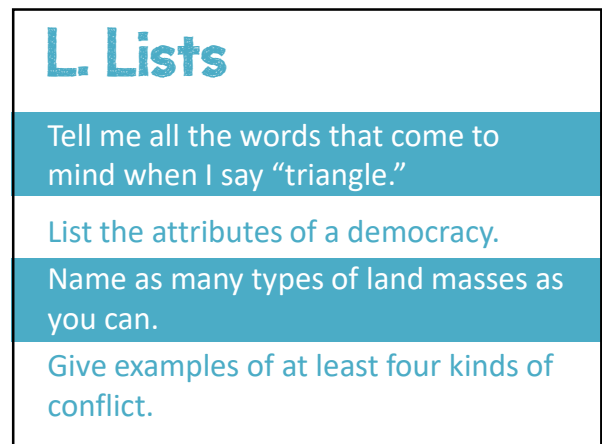

48





49

### N. New to Me

Mrs. Van, these things are new to me:

- Fractions in general
- Common denominators
- How to add fractions
- Reducing fractions
- How to tell which fractions are bigger

50

### O. Open-ended Questioning

- Why do you think Cassius was successful in swaying Brutus to his side?
- What do you think will happen if I add \_\_\_\_\_ to \_\_\_\_\_?
- How is \_\_\_\_\_ harder than \_\_\_\_\_?

51

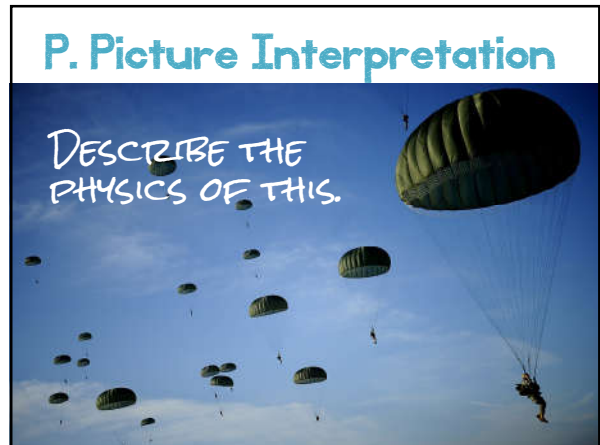

52

### Q. Quick Write

TELL ME EVERYTHING YOU KNOW ABOUT WHY THE US DELAYED ENTERING WWII & DESCRIBE YOUR AGREEMENT/DISAGREEMENT.

53



54

**S. Student Demonstration or Interviews**



55

**T. Traditional Test**



56

**U. Upside Down & Backwards**

GIVE THE  
HARDEST  
QUESTION

57

**V. Very, Very, Quite Contrary**

The hardest  
thing about  
\_\_\_\_\_ is \_\_\_\_\_.

58

**W. Writing Evaluation**

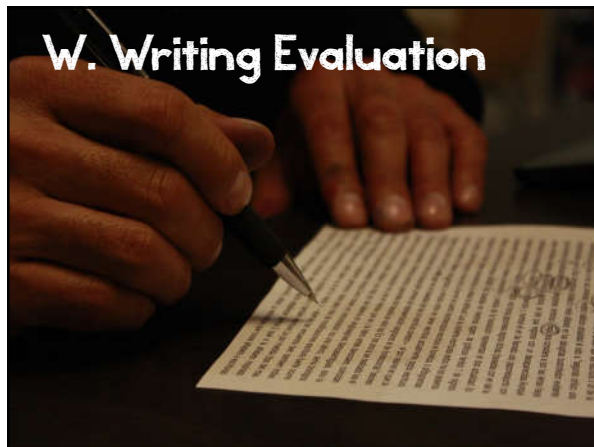

59

**X. X-Ray the Topic**

What are the  
bones of the  
idea of  
\_\_\_\_\_?



60

**Y. Yes/No Cards**  
(esp. with vocabulary)

61

**Z. Zebra Got its Stripes**  
{most unusual thing}

62

**Use what you've got.**

3 The caterpillars of monarch butterflies eat milkweed leaves. Milkweed leaves contain sap that is toxic to many animals but not to monarch butterfly caterpillars. This sap makes the monarch butterfly caterpillars toxic to predators and protects them from being eaten.

Which of these is an inherited trait of monarch butterfly caterpillars?

- A The size of the milkweed leaves that the caterpillars eat
- B The ability of the caterpillars to eat toxic leaves without being harmed
- C The number of milkweed leaves the caterpillars eat each day
- D The number of leaves on the milkweed plants that the caterpillars visit each summer

63

1 Mari bought 6 packets of tomato seeds. Each packet contained 24 seeds. She planted 1 packet of the seeds, and 15 seeds sprouted.

Which statement about the seeds in the remaining packets is best supported by this information?

- A No more than 50 seeds will sprout.
- B Between 50 and 100 seeds will sprout.
- C At least 100 but no more than 120 seeds will sprout.
- D All 120 seeds will sprout.

64

**You Try It Right Now**

*bit.ly/staar-released*

65

**Talking the Talk**

*Be prepared to answer questions and have hard conversations with students and parents (see handout)*

66

*If they waste the opportunity, they lose it for next time.*

67

*What is pre-assessment?*

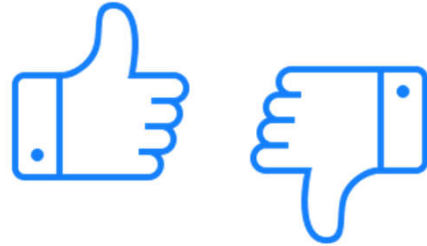

68

*When will we use it?*

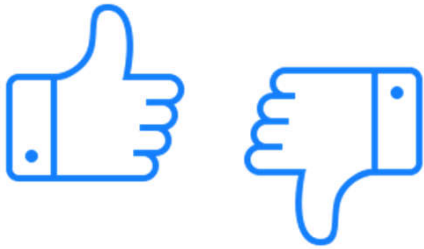

69

*What will it look like?*

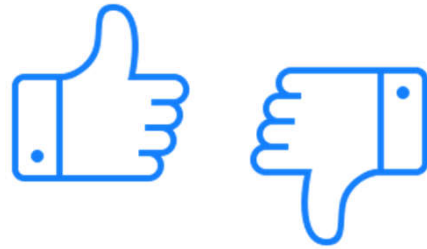

70

*What will it tell me?*

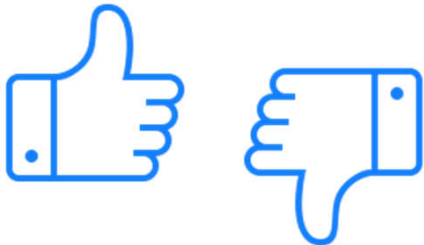

71

*Will the score “count”?*



72

Will you share grades with parents?



73

What will happen as a result of it?



74